



**NOVA TESTINGS PTE LTD**  
280 Woodlands Industrial Park E5  
#02-41 Harvest @ Woodlands Singapore 757322  
Tel: +65 6561 1002/6 Fax: +65 6561 2003  
E-mail: sales@novatestings.com  
Website: www.novatestings.com

## 2300 Comp Load Cell

---

### Compressive Load Cell

- Range 50 to 1000te
- Stainless steel construction.
- Rugged and easily employed
- Sealed to IP67



## Description

The 2300 compressive load cell has full environmental protection and is built for rugged applications. The load cell is constructed from high strength stainless steel. A complete range covers the load capacities from 50 tonne up to 1000 tonne. Each load cell is fitted with a domed loading cap that can have loading restraints. The loading cap helps to offset any errors due to eccentric loading and also accommodating uneven loading surface. The cable exit is via robust gland or connectors.

## Specification

### ELECTRICAL

- Recommended excitation 10 Vdc.
- Maximum excitation 15 Vdc.
- Output at rated load 2.0mV/V
- Zero balance 5% of RL
- Input impedance 700ohms +/-20
- Output impedance 700ohm +/-3
- Insulation  $>10^9$ ohms
- Compensation temp range 10 to 60 C
- Safe temp range -30 to 70 C

### MECHANICAL

- Safe overload 150% of RL
- Ultimate overload 300% of RL
- Deflection  $<0.5$ mm
- Cable type 4 core screened
- Cable length 10 M
- Sealed IP67

## Accuracy

- Non linearity & hysteresis 0.20%
- Non repeatability  $<0.10$ %
- Zero return (after 30 mins). 0.05%
- Temp effect/10deg C on zero 0.02%
- Temp effect/10deg C on span 0.02%

## Wiring

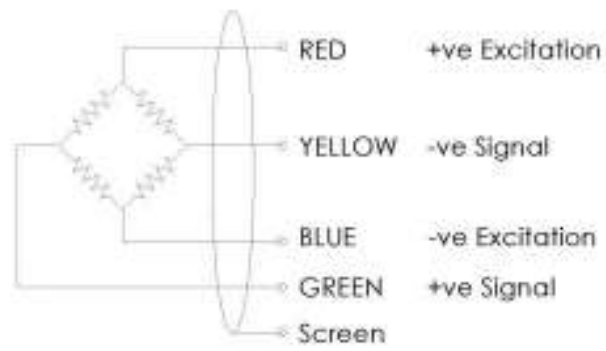

## Drawing

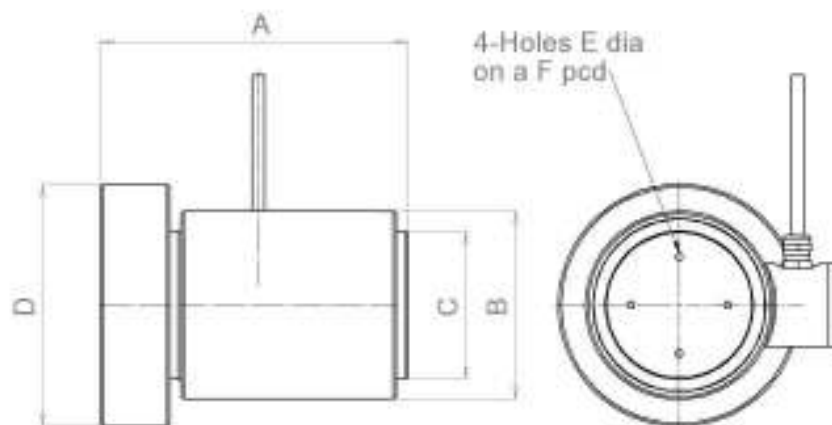

## Dimensions

RATING	A	B	C	D	E	F	Remarks
te	mm	mm	mm	mm	mm	mm	
50	170	108	88	145	M6	60	
150	170	108	88	145	M6	60	
200	170	108	88	145	M6	60	
300	223	134	107	175	M6	70	
500	295	165	138	225	M8	90	
1000	362	203	175	270	M10	150	
1500	438	250	220	300	M10	160	

## Additional Notes

Specification may change without notice