

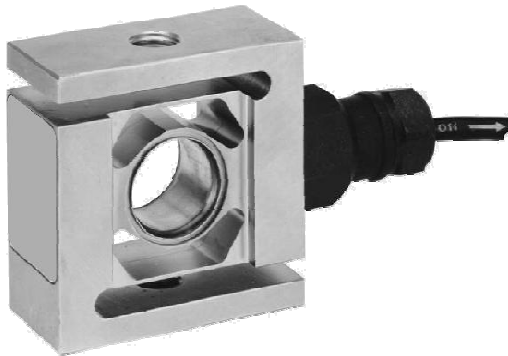

NOVA TESTINGS PTE LTD
280 Woodlands Industrial Park E5
#02-41 Harvest @ Woodlands Singapore 757322
Tel: +65 6561 1002/6 Fax: +65 6561 2003
E-mail: sales@novatestings.com
Website: www.novatestings.com

Type UB6 load cell



- **High Accuracy**
- **Stainless Steel Construction**
- **Resistant to off axis loads**
- **Allows vessel expansion**

Description

Flintec loadcells are designed to meet the most stringent accuracy requirements. Certifications have been obtained from Weights & Measures Authorities , worldwide.

SB4 loadcells are available in the capacities 5 kN to 100 kN (510kg to 10197kg) and include Accuracy Classifications GP, C1, C3, C3 MI 7.5, C4 and C4 MI 7.5 according to OIML R 60; NTEP n max=5000.

They offer total stainless steel construction and complete hermetic sealing, making them suitable for use in the toughest industrial environments.

The unique "blind" loading hole combined with the available Flintec loading hardware provides an excellent price-performance ratio.

It allows very low profile platform design and offers advantages in all kinds of weighing applications. The Flintec calibration technique (inmV/V) eliminates time consuming corner calibration in multiple load cell systems. The UB6 is available for use in hazardous areas zone 1, 2 (gas) and 21, 22 (dust) according to EExia IIC T6...T4 T130°CATEX.

Dimensions

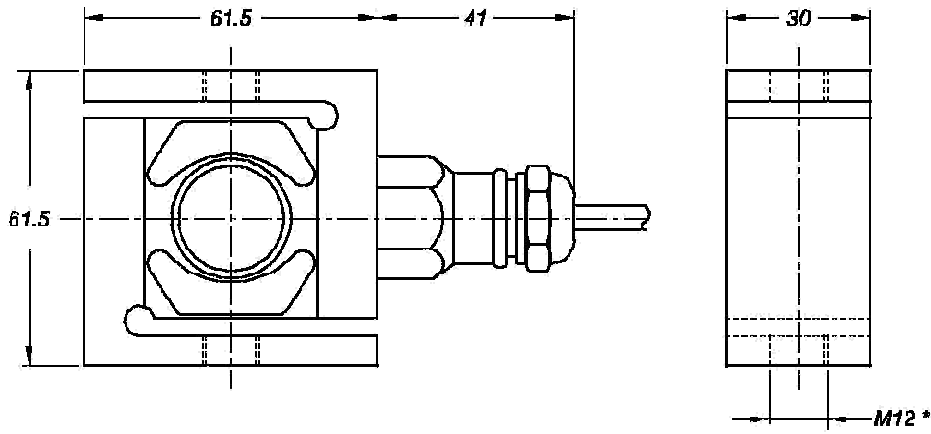

All dimensions in mm. Dimensions and specifications are subject to change without notice.

* Unified thread 1/2-20 UNF is available.

UB6 Specifications

Maximum capacity (=E _{max})	kN	1 / 2 / 5			
Metric equivalents (1 N=0.10197 kg)	kg	102 / 204 / 510			
Rated Output (=RO)	mV/V	2 ± 0.1%			
Calibration in mV/V/ (A...I classified)	%RO	± 0.05 (± 0.005)			
Accuracy class according to OIML R 60		(GP)	C1	C3	C3 MR
Maximum number of verification intervals (n)		n.a.	1000	3000	3000
Minimum load cell verification interval (v _{min})		n.a.	E _{max} /5000	E _{max} /10500	E _{max} /20000
Combined error	%RO	± 0.040	± 0.030	± 0.020	± 0.020
Creep error (30 minutes)	%RO	± 0.060	± 0.049	± 0.024	± 0.024
Temperature effect on minimum dead load output	%RO/°C	± 0.0040	± 0.0028	± 0.0012	± 0.0007
Temperature effect on sensitivity	%/°C	± 0.0020	± 0.0016	± 0.0011	± 0.0011
Excitation voltage	V	5...15			
Zero balance	%RO	± 1.0			
Input resistance		1106 ± 5			
Output resistance		1000 ± 1			
Insulation resistance	M	5000			
Compensated temperature range	°C	-10...+40			
Operating temperature range	°C	-40...+85			
Safe load limit	%E _{max}	200			
Ultimate load	%E _{max}	300			
Load cell material		stainless steel 17-4 PH (1.4548)			
Sealing		complete hermetic sealing; cable entry sealed by glass to metal header			
Protection according DIN 40.050		IP68			

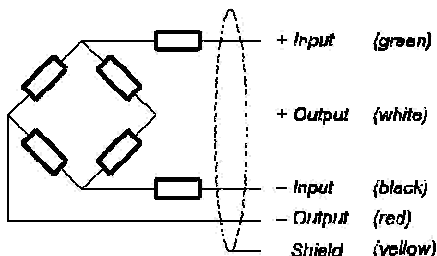

Wiring

- The load cell is provided with a shielded, 4 conductor cable.
- Cable length: 3 m
- Cable diameter: 5 mm
- The shield is connected to the load cell body.

Note:

Maximum errors (+/-) are expressed as a percentage of rated load (when measured at 10Vdc excitation). The linearity and hysteresis is the maximum deviation from a straight line drawn between the no load and the rated load outputs for both increasing and decreasing loads. Accuracy classes apply when active range (live weight) is within 20 to 90% of rated load.